



# SMARTSIDE®

TRIM & SIDING

## FOUNDATIONS 76 SERIES PRIMED LAP SIDING ARCHITECTURAL COLLECTION 76 SERIES PRIMED COLONIAL AND 120 SERIES PRIMED SELF-ALIGNING LAP SIDING

### GENERAL

- At the time of manufacture, siding meets or exceeds the performance standards set forth in Composite Panel Association ANSI 135.6-2006 and has achieved code recognition under Legacy National Evaluation Report NER-626 and CCMC-12353L. For copies of these reports, call LP Customer Support at 1-800-577-4836.
- Minimum 6 in. clearance must be maintained between siding and finish grade.
- Siding applied adjacent to porches, patios, walks, etc. must have a clearance of at least 1 in. above any surface.
- Minimum 1" clearance at intersection with roof line
- Apply siding in a manner that prevents moisture intrusion and water buildup.
- All exposed wood substrate must be primed and painted in a manner that prevents moisture intrusion and water buildup.
- In non-traditional ICF and SIP assemblies, the ICF or SIP manufacturer must prescribe the fastening specifications. Note: LP does not recommend LP SmartSide for use in these non-traditional assemblies. If used, LP will not warrant for Buckling and Shrinkage. However, balance of warranty does remain intact.
- When using wet blown cellulose insulation, adequate drying time must be allowed prior to enclosing the wall cavity
- DO NOT USE STAPLES

### STORAGE

- Store off the ground well supported, on a flat surface, under a roof or separate waterproof covering
- Keep siding clean and dry. Inspect prior to application.
- Allow siding to adjust to atmospheric conditions before application.

### STUD SPACING

- Foundations 76 Series lap siding may be applied over sheathed walls or, where building codes permit, directly to studs spaced no greater than 16 in. O.C. that have adequate corner bracing.
- In all installations over masonry walls, the wall must be furred out with framing spaced 16 in. O.C. and with adequate thickness to accept the full length of the recommended nail.
- Foundations 76 Series and Architectural Collection 76 series primed colonial lap siding is not warranted against buckling in Alaska, Hawaii, Northern California or west of the Cascades in Washington, Oregon and California.

### MOISTURE

- Moisture control and moisture vapor control are critical elements of proper housing design. Check your local building codes for application procedures for handling moisture and moisture vapor in your area.
- As with all wood products, do not apply engineered wood siding to a structure having excessive moisture conditions such as drying concrete or plaster. If such conditions exist, the building should be well ventilated to allow it to dry prior to the application of the siding.

- Siding must not be applied to green or crooked structural framing members. Do not apply siding over rain-soaked or buckled sheathing materials.
- Gutters are recommended for control of roof water run off.

### VAPOR RETARDER/WEATHER BARRIER

- A properly installed breathable water-resistive barrier is required behind the siding.
- Consult your local building code for details.
- LP will assume no responsibility for water penetration.

### GAPS & SEALANTS

- Seal all gaps with a high-quality, non-hardening, paintable sealant with a minimum stated service life of 30 years. Follow the sealant manufacturer's instructions for application.

### FLASHING, WINDOWS, DOORS & OPENINGS

- All openings must be properly sealed or flashed in a manner that prevents moisture intrusion or buildup. Several examples that accomplish this are shown on the following pages.

### TRIM

Trim should be thick enough so the siding does not extend beyond the face of the trim.

- Trim and fascia must be applied in a manner that will not allow moisture intrusion or water buildup.
- LP® SmartSide® siding are not designed and/or manufactured to be used as trim or fascia. LP SmartSide trim and fascia are available in a variety of dimensions.

### FINISHING INSTRUCTIONS

#### DO

- Priming all exposed wood substrates before painting is highly recommended.
- Paint all exposed siding surfaces including drip edges.
- Thoroughly paint the bottom edges of siding especially all cut ends next to the roof line.
- Apply paint as soon as possible and within 180 days of application.
- Follow the coating manufacturer's application and maintenance instructions.
- High-quality acrylic latex paint, specially formulated for use on wood and engineered wood substrates, is highly recommended. Semi-gloss or satin finish oil or alkyd paints are acceptable. For flat alkyd paint, please check with the coating manufacturers for their recommendations for use on composite wood siding.

## SIDING APPLICATION INSTRUCTIONS

- a) Apply siding over a maximum stud spacing of 16 in. O.C. (See General Information)
- b) Begin by establishing a straight reference line to guide positioning the bottom edge of the first course of siding.
- The suggested procedure is to measure equal distance downward from the eaves and/or windows and snap a chalk line.
- This first step ensures that the siding appears parallel with the eaves, soffit, and windows, regardless of any actual setting of the house from true level.
- SIDING MUST BE APPLIED AT LEAST 6 in. ABOVE THE GROUND.**
- c) Snap parallel chalk lines on the walls as guides in positioning the top edge of each siding course. Space chalk lines so that (1) bottom edge of the first course of siding is applied at least 6 in. above the ground, and (2) that each subsequent siding course is overlapped a minimum of 1 in. (minimum 1-3/8 in. for Beaded Lap Siding).
- d) Nail a starter strip (wood lath or siding approximately 3/8 in. x 1-1/2 in.) 1/4 in. above bottom chalk line and install first course of siding.
- e) Nail at all stud locations; position nails 3/4 in. from the bottom edge of siding (1 in. for Beaded Lap Siding) in order to penetrate both siding courses. Nail 3/8 in. from butt ends.
- f) **NAILS MUST PENETRATE FRAMING MEMBERS AT LEAST 1-1/2 in.**
- For best performance use hot-dipped galvanized nails with a minimum 1/4 in. diameter head.
- Shim siding at studs, as needed, to avoid drawing siding against uneven walls. **DO NOT OVERDRIVE NAILS.** Nail head should seat firmly to face of siding but not be overdriven to distort the siding surface.
- g) When installing siding over maximum 1 in. foam sheathing, care must be taken not to drive nails so hard as to compress the foam and distort the siding surface.
- h) Vertical butt joints must fall on studs. Nails should be placed at all stud locations and positioned 3/8" from the vertical edges on each side of the butt joint. Stagger butt joints on subsequent courses.
- Leave a 3/16 in. gap. All joints must be sealed. Optional joint covers may be used.
- Sealant must be a high-quality, non-hardening, paintable sealant.
- i) Nail at all special framing members around openings (maximum spacing 16 in. O.C.). Shim, if necessary, to provide solid backing for siding fitted around windows, doors, and at rake cuts on gable ends.

## SIDING APPLICATOR INSTRUCTIONS (CONTINUED)

- j) Where siding butts against window and door trim and at wood inside and outside corners, leave a 3/16 in. gap and seal.
- Nail from the center of the plank toward the ends, or from one end to the other end. **NEVER** nail from the ends of the plank toward the middle.
- k) Corner posts can be metal, wood, or vinyl. Trim should be thick enough so the siding does not extend beyond the face of the trim.
- l) Use drip cap flashing above all openings to ensure a weather-tight installation.
- m) SmartSide Siding may be sawn face-up with a fine-tooth hand-saw or face down with a combination blade power saw.

The Louisiana-Pacific Corporation ("LP") LP SmartSide Siding (the "Products") limited warranty (the "Warranty") applies only to structures on which the Products have been applied, finished and maintained in accordance with the published application, finishing and maintenance instructions in effect at the time of application. The failure to follow such application, finishing or maintenance instructions will void the Warranty as to the portion of the Products affected by the variance (the "Affected Products").

LP assumes no liability for any loss or damage sustained by the Affected Products and is expressly released by the purchaser or owner from any such loss or liability.

Any modification of the Warranty's application, finishing or maintenance requirements is void and unenforceable unless approved in writing prior to application by the Siding General Manager or his designee and a member of the LP Legal Department.

For a copy of the warranty or for installation and technical support, visit the LP SmartSide product support Web site at:

**www.lpcorp.com**

or for additional support call 800.450.6106.

**WARRANTY REMEDIES ARE NOT AVAILABLE IF REQUIREMENTS ARE NOT FOLLOWED.**



© 2010 Louisiana-Pacific Corporation. All rights reserved. LP and SmartSide are registered trademarks of Louisiana-Pacific Corporation. Printed in U.S.A.

NOTE: Louisiana-Pacific Corporation periodically updates and revises its product information. To verify that this version is current, call 800-450-6106.

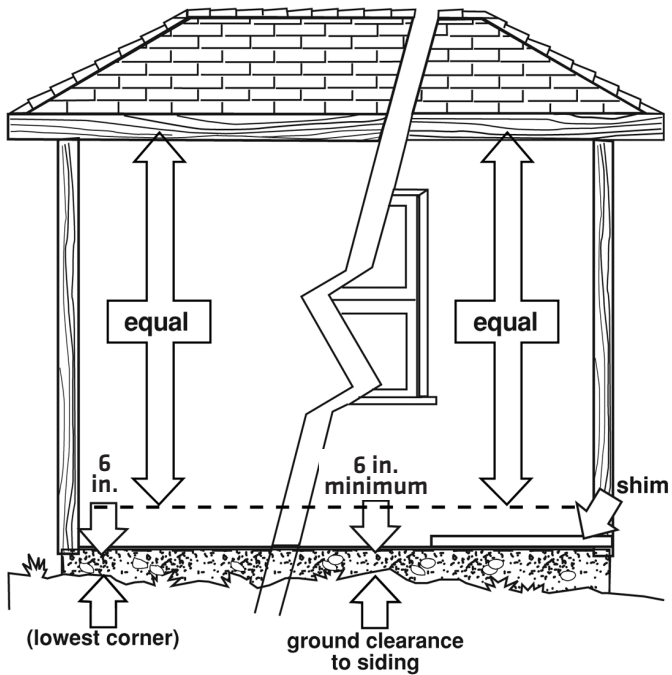
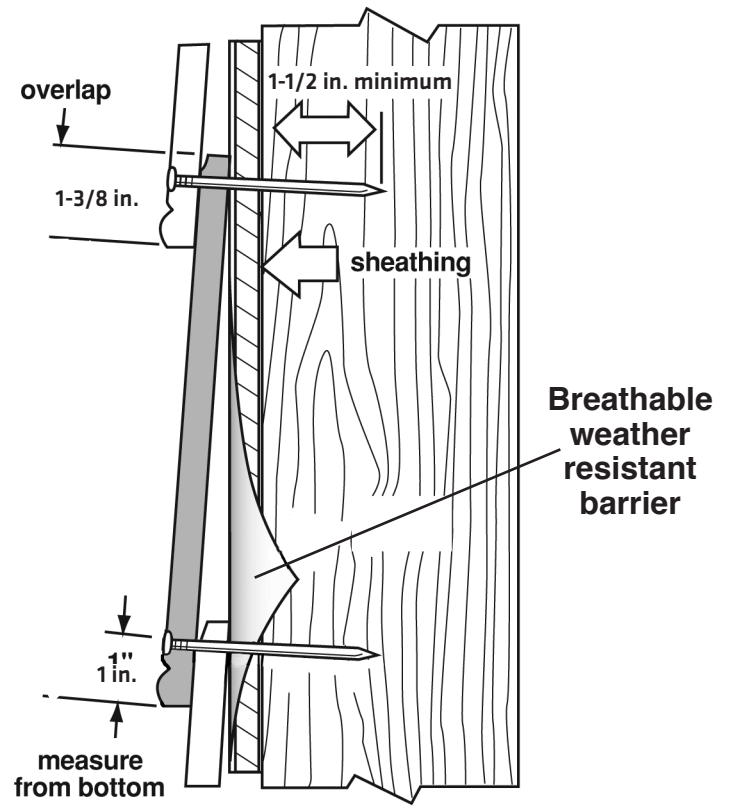
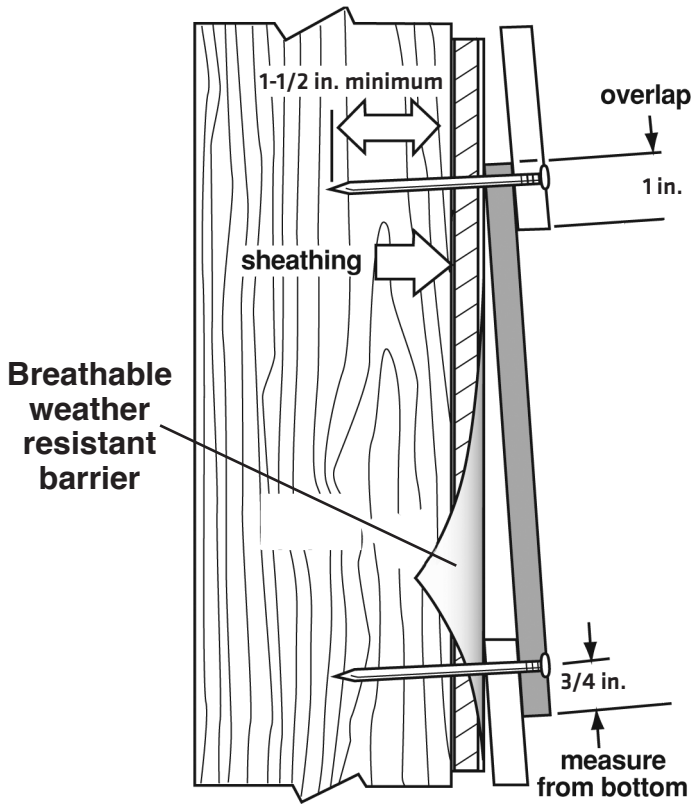

**establish straight reference lines**

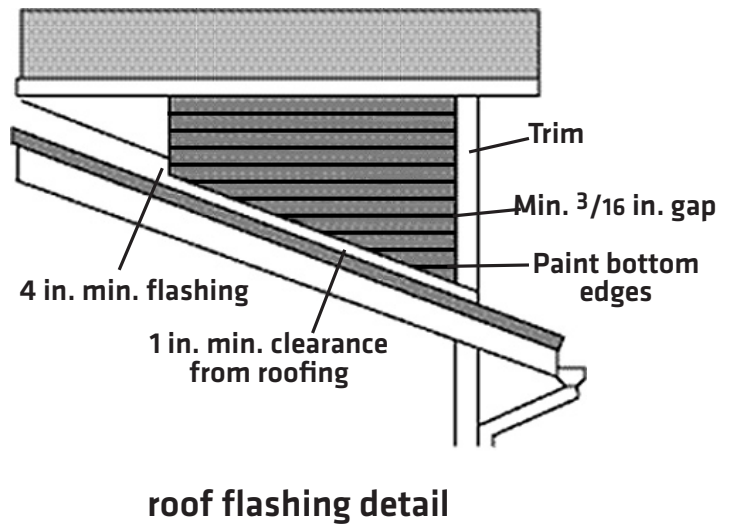

### over openings

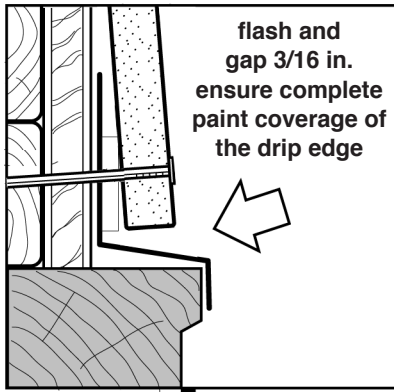

### joint treatment

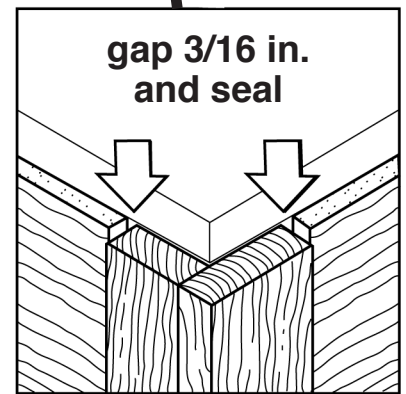
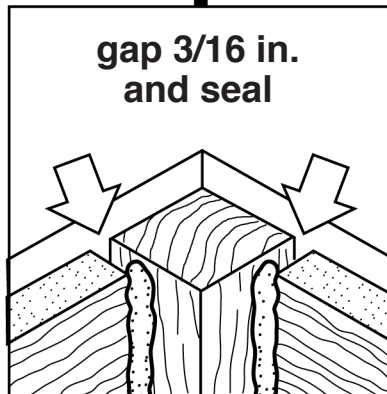
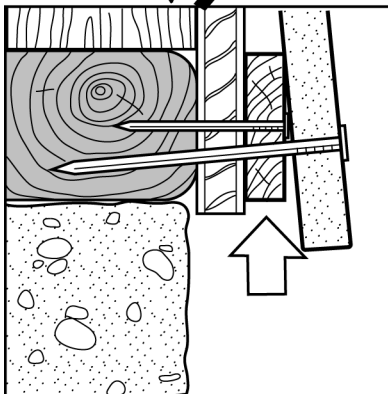
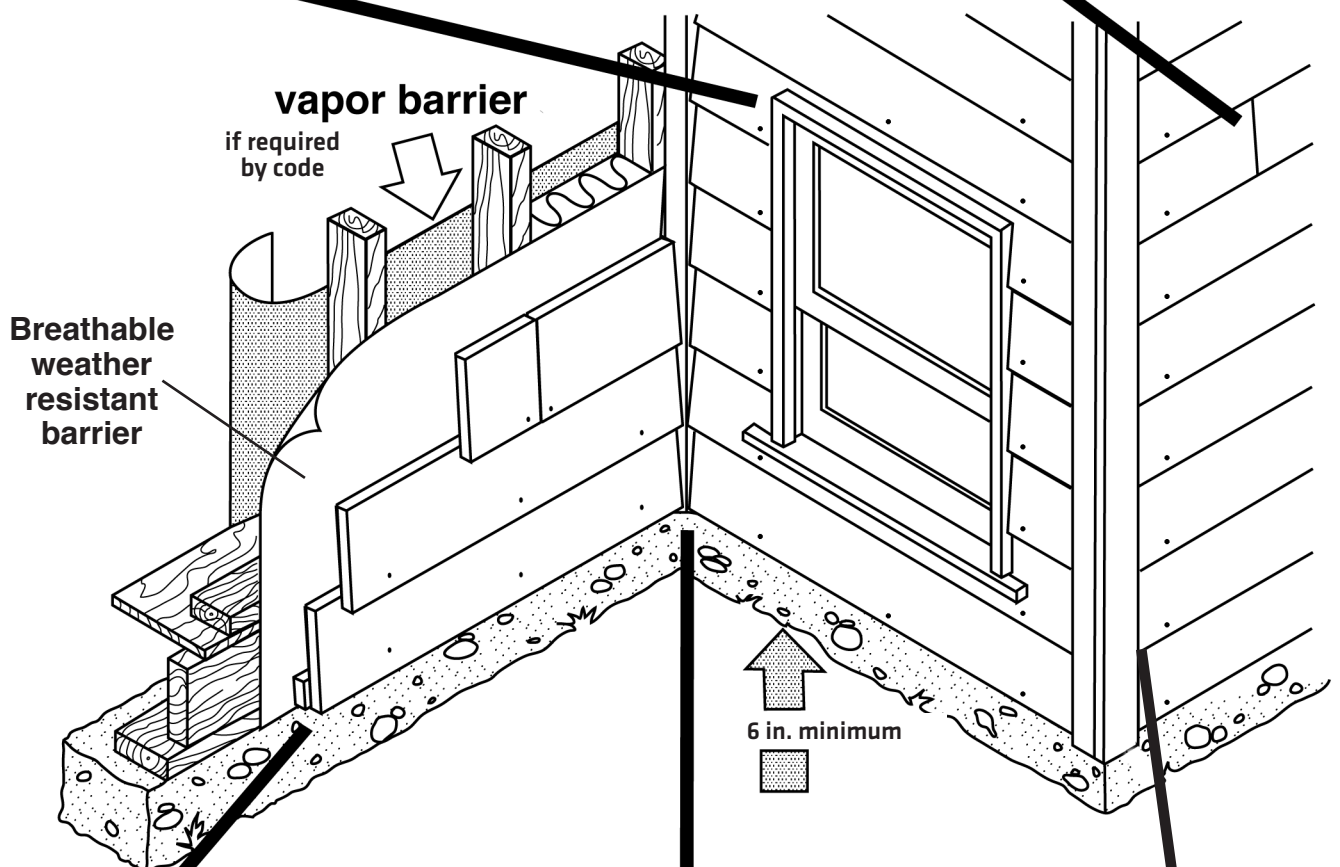
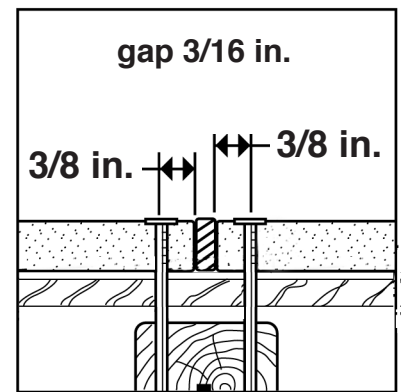
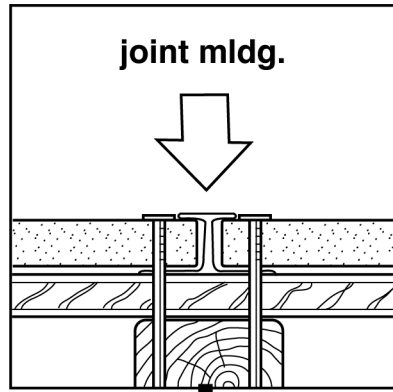

bottom course detail

inside corner detail

outside corner detail